

TransAlta

Tempest Wind Project Connection

About The Project (What is the project?)

TransAlta Coaldale Wind L.P. by its General Partner TransAlta Coaldale Wind Inc. (TransAlta) is proposing to construct approximately 20 km of new 138-kilovolt (kV) transmission (Project) to the Alberta Interconnected Electric System (AIES). This Project would connect the approved Tempest Wind Power Project to the provincial power grid. The proposed Project will be situated between the approved Tempest 1082S substation which is located on SE-19-7-17-W4M and connecting to the existing, AltaLink Management Ltd, owned 138 kV line north of the Chin Reservoir. AltaLink will be engaging stakeholders regarding the potential connection portion of the proposed project and any other additional upgrades required and will submit a separate facility application to the AUC.

Wind Farm (What is the windfarm?)

TransAlta has received approval from the Alberta Utilities Commission (AUC) to develop, build and operate the Tempest Wind Power Project (Tempest). The approved generation site is located approximately 24 km south of Taber and would generate a targeted capacity of 99 Megawatts (MW).

What will The Project Consist Of?

- + Overhead transmission wires
- + Transmission structures
- + Telecommunication wires
- + Permanent easements
- + Temporary workspace
- + Access roads
- + Laydown areas

Routing Selection & Details (How did we come up with the routes?)

Several factors are considered in an effort to plan a transmission line route with the least overall impact. Some of the factors considered include:

- + existing land use
- + environmental and agriculture impacts
- + existing and proposed infrastructure
- + proximity to residences
- + economic viability and cost
- + engineering constraints

The enclosed maps show preliminary route options. The options are designed based on the factors considered. The proposed transmission line routing alignment primarily follows county road allowances.

Routes currently shown are for engagement and planning purposes, and TransAlta would like to hear feedback from interested parties in the area.

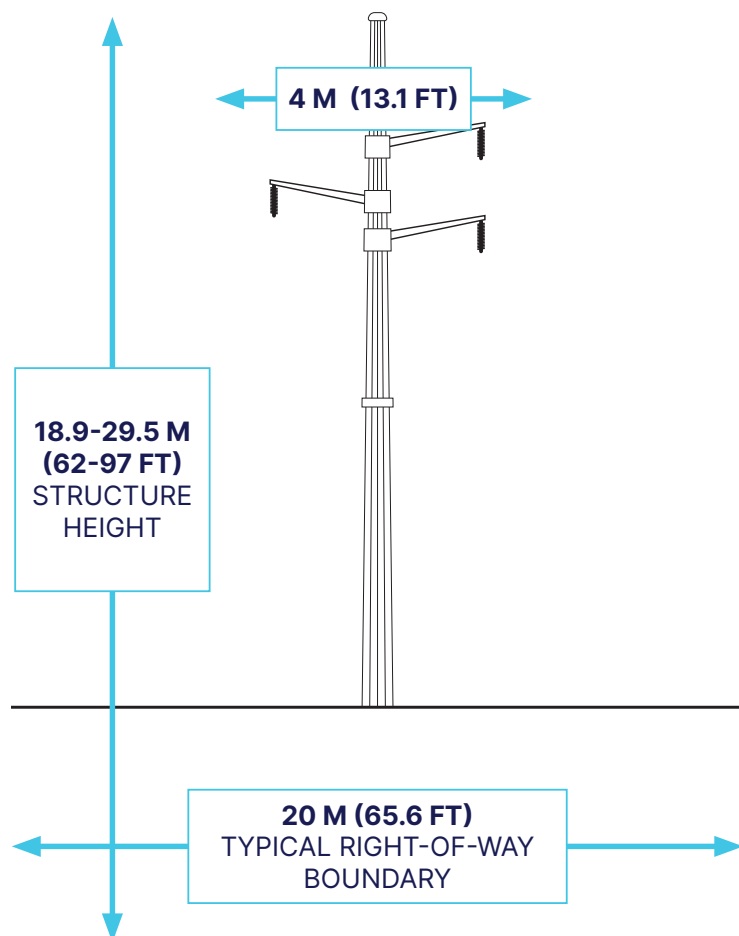

What Will This Project Look Like?

The Project will primarily consist of single pole structures, similar to the diagram. Most of the structures will be spaced approximately 150 m (492 ft) apart. Alternative specialty structures will be required at corners, reservoir crossing, longer spans, and at the connection point. A line switch structure will be required near the connection point to provide an isolation point for emergency purposes and maintenance of the transmission line. Final structure types have not been determined and will be shared with the community once finalized. Structure placement will be based on engineering constraints and conversations with community members.

Proposed Schedule* (What is the timeline?)

The overall timeline being proposed for the project is as outlined:

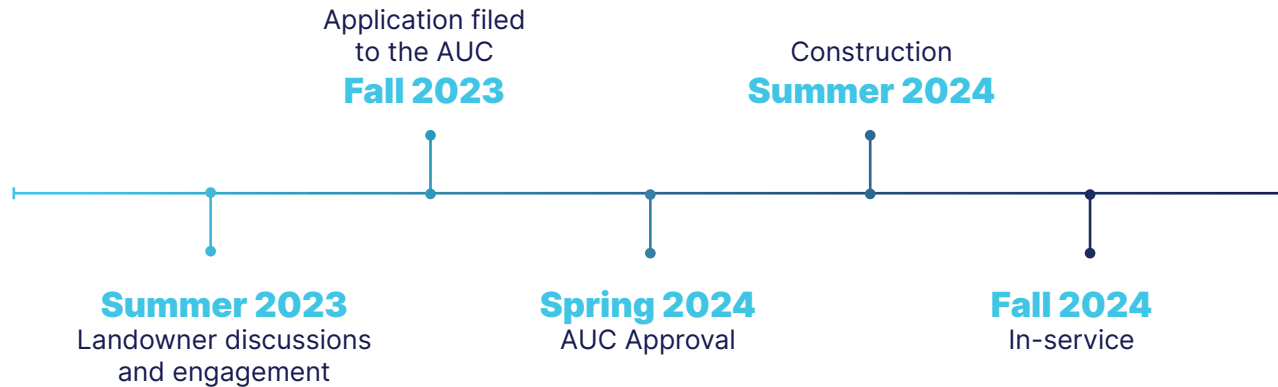

*Subject to change

Who is the Alberta Electric System Operator (AESO)?

The Alberta Electric System Operator (AESO) is an independent, not-for-profit organization responsible for the safe, reliable, and economic planning and operation of the provincial transmission grid. For more information about why this project is needed, please refer to the AESO's Need Overview included with this package or visit www.aeso.ca. If you have any questions or concerns about the need for this project or the proposed transmission development to meet the need, you may contact the AESO directly. You can make your questions or concerns known to a transmission facility owner representative who will collect your personal information for the purpose of addressing your questions and/or concerns to the AESO. This process may include disclosure of your personal information to the AESO.

- + 1-888-866-2959
- + stakeholder.relations@aeso.ca
- + www.aeso.ca

Who is the Alberta Utilities Commission (AUC)?

The Alberta Utilities Commission (AUC) is an independent, quasi-judicial agency of the province of Alberta. The AUC is responsible to ensure that the delivery of Alberta's utility service takes place in a manner that is fair, responsible and in the public interest. The AUC will make the final decision on this Project. TransAlta will submit preferred and alternate(s) routes to the AUC in a facility application in Fall of 2023.

Are There Other Groups Involved With The Project?

The Tempest Wind Power Project is eligible to be developed and constructed under the Market Participant Choice (MPC) option; this means the Project will be permitted and constructed by TransAlta. Once the line is in-service, TransAlta will transfer the Project to AltaLink who will assume role of Transmission Facility Owner (TFO) and operator of the transmission line.

What We Need From You?

TransAlta is seeking feedback from landowners, residents, and interested parties. We are looking for feedback about routing, information about landholdings, and any other local knowledge to help guide our project planning.

Please reach out to our team:

Email: transaltatempest@maskwaenv.com

Phone: 1-888-474-1702

Website: www.transalta.com/about-us/our-operations/projects-in-development/tempest

